

Phoenix Precision's N6M mini valves are built for the engineer and the instrumentation technician. Using barstock construction and a robust stem, Phoenix's design assures a bubble tight seal in a variety of conditions. Bonnets are pinned for security. The globe-pattern flow provides maximum shut-off, with a variety of special stem tips, materials and configurations to meet most customer requirements. Phoenix mini bonnets feature packing below the threads to prevent process contamination unlike many of its competitors. All Phoenix valves are built and tested in accordance with MSS-SP105, which includes hydrostatic testing of the body at 150% rated pressure, seat leakage test of 150% rated pressure, and material test reports on body and bonnet as standard.

Phoenix Precision has taken the guess work out of specifying valves. Phoenix Precision valves are designed and tested to meet or exceed the specifications below:

- ▶ ASME B31.1 Power Piping
- ▶ ASME B31.3 Process Piping
- ▶ MSS SP-61 & ASME B16.34
- ▶ API 598 Valve Inspection and Testing
- ▶ MSS-SP105 Instrument Valves for Code Applications
- ▶ MSS-SP99 Instrument Valves
- ▶ MSS-SP25 Standard Marking Systems for Valves, Fittings, and Flange Unions
- ▶ NACE MR0175/ISO 15156 for all 316SS valves and A105CS body/316SS bonnet (SC-Material Code) valves in services with less than 50 ppm of chlorides

- ▶ ISO 9001:2000(E) Certified
- ▶ ABSA Registered Design CRN# 0C06740.2

- ▶ All valve assemblies are hydrotested at 150% of rated pressure as standard (shell test)
- ▶ All valves assemblies pass a seat leakage test at 150% of rated pressure as standard (seat test)
- ▶ MTR's on body, bonnet, and stem as standard
- ▶ All pressure component materials are sourced from U.S., Canada or Europe
- ▶ All packing below stem threads to prevent corrosion and contamination
- ▶ Metal body to bonnet seals are in compression not tension
- ▶ Back-seating to prevent stem blowout and provide a metal to metal secondary stem seal in full open position
- ▶ All stem threads are rolled for superior strength and to prevent galling
- ▶ O-ring stem seals come with additional Teflon™ top and bottom back-up rings
- ▶ Dust cap keeps contaminants out of bonnet assembly



N6M™ SERIES
Minivalve O-ring Bonnet



N6M™ SERIES
Minivalve Packed Bonnet

O-ring Bonnet Minivalve

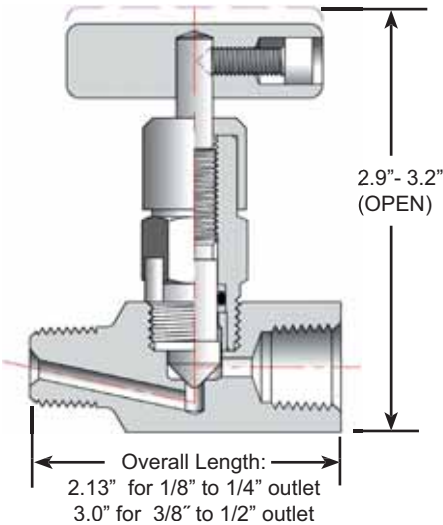

Specifications:

Type: Mini-valve, Globe Pattern
 Rating: up to 6000 psi @ 100°F
 (41370 kPa @ 38°C)
 Stem: Needle tip or Ball tip
 Packing: FKM or AflasTM O-ring
 Seat: Integral, PeekTM, DelrinTM or Kel-FTM
 Handle: Removable
 Bore Size: 1/8"
 Inlet Connections: 1/8" to 3/4" NPT, SW or FT
 Outlet Connections: 1/8" to 1/2" NPT, SW or FT
 Bonnet Lock: Pin or Plate
 Body Stock: .875" sq to 1.125" sq
 Weight: 0.6 - 1.3 lbs
 Special Service: O₂ or CL cleaning available*
 *Other specifications or services may be available.

Materials of Construction

CODE	SS	SC	CS
Body	ASTM A182 316SS	ASTM A105CS	ASTM A108CS
Bonnet	ASTM A182 316SS	ASTM A182 316SS	ASTM A108CS
Stem	ASTM A182 316SS	ASTM A182 316SS	ASTM A582 303SS
Insert	ASTM A182 316SS	ASTM A182 316SS	ASTM A108CS
Handle	ASTM A582 303SS	ASTM A582 303SS	ASTM A108CS

Packed Bonnet Minivalve

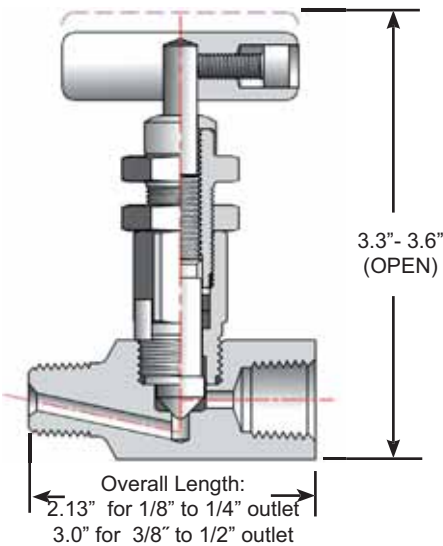

Specifications:

Type: Standard Valve, Globe Pattern
 Rating: up to 6000 psi @ 100°F
 (41370 kPa @ 38°C)
 Stem: Needle tip or Ball tip
 Packing: PTFE or GrafoilTM
 Seat: Integral, PeekTM, DelrinTM or Kel-FTM
 Handle: Removable
 Bore Size: 1/8"
 Inlet Connections: 1/8" to 3/4" NPT, SW or FT
 Outlet Connections: 1/8" to 1/2" NPT, SW or FT
 Bonnet Lock: Pin or Plate
 Body Stock: .875" sq to 1.125" sq
 Weight: 0.7 - 1.4 lbs
 Special Service: O₂ or CL cleaning available*
 *Other specifications or services may be available.

Materials of Construction

CODE	SS	SC	CS
Body	ASTM A182 316SS	ASTM A105CS	ASTM A108CS
Bonnet	ASTM A182 316SS	ASTM A182 316SS	ASTM A108CS
Stem	ASTM A182 316SS	ASTM A182 316SS	ASTM A582 303SS
Adjuster	ASTM A582 303SS	ASTM A582 303SS	ASTM A108CS
Insert	ASTM A182 316SS	ASTM A182 316SS	ASTM A108CS
Handle	ASTM A582 303SS	ASTM A582 303SS	ASTM A108CS

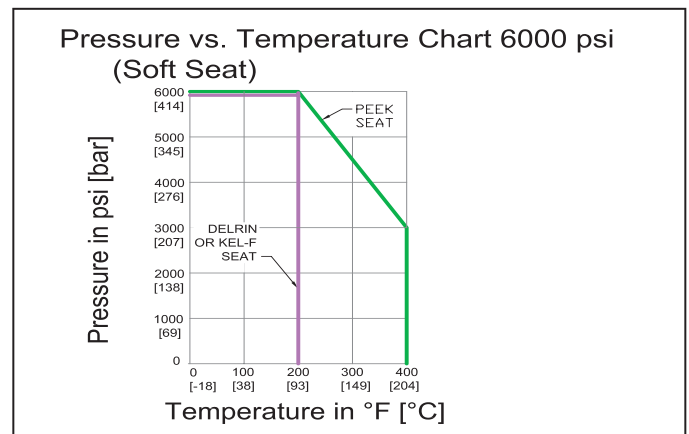
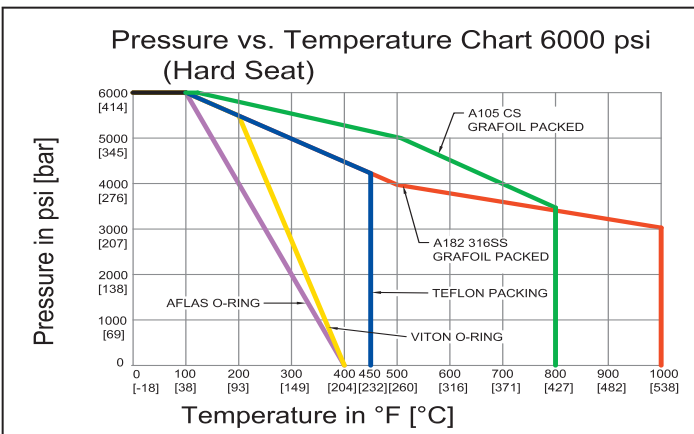

Note: Body material specifications based on ASME B16.34 - 2004. Packing materials based on manufacturer's specifications. Approximations only. Phoenix does not represent these values as finite. They are provided only as representative values.

MODEL NUMBERING SYSTEM

Phoenix	Orifice Size	Type	Inlet Size	Inlet Type	Outlet Size	Outlet Type	Material	Packing	Seat	Stem Tip
P	2=1/8"	N6M	2=1/8"	F=FNPT	2=1/8"	F=FNPT	SS=ASTM A182 316/316L	A=Aflas™	Integral (leave blank)	Needle Tip Standard (leave blank)
			4=1/4"	M=MNPT	4=1/4"	M=MNPT	SC=ASTM A105 CS**	V=FKM	D=Delrin™	B=316SS Ball Tip
			6=3/8"	MS*=Male Socketweld	6=3/8"	MS*=Male Socket eld	CS=ASTM A108 CS**	T=PTFE	P=Peek™	BC=Ceramic Ball Tip
			8=1/2"	FS*=Female Socketweld	8=1/2"	FS*=Female Socketweld	C5=ASTM A350 LF2	G=Grafoil™	K=Kel-F™	BM=Monel™ Ball Tip
			12=3/4"	FT=Female Tube Fitting		FT=Female Tube Fitting	N4=Monel™ 400			
							N6=Inconel™ 625			
							N8=Inconel™ 825			
							N2=Hastelloy™ C276			
EXAMPLE: P2N6M4M4FCSVD = 1/8" Orifice, 1/4" MNPT Inlet, 1/4" FNPT Outlet, A108 CS Body, FKM Packing, Delrin™ seat, Needle Tip Stem										
P	2	N6M	4	M	4	F	CS	V	D	
*For socket weld (SW) connections, specify MS or FS **For code applications, A108 CS is unacceptable, A105 CS must be selected for CS valves.										

OPTION CODES	DESCRIPTION
LB	Bonnet Lock
CC	Chlorine Clean
OC	Oxygen Clean
TG	SS Tag
SGL	Sour Gas ISO Nace Latest Rev.
RA(R)(B)	Round Handle Aluminum (Red)(Blue)
RC	Round Handle C.S.
RS	Round Handle S.S.
PM	Panel Mount
N4	Monel™ 400 Stem
N5	Monel™ 500 Stem
N6	Inconel™ 625 Stem
N8	Inconel™ 825 Stem
N2	Hastelloy™ C276 Stem

SEAL & SEAT MATERIAL TEMPERATURE RATING

Code	Description	MIN. TEMP	MAX. TEMP
A	Aflas™	15°F (-10°C)	400°F (204°C)
V	FKM	-20°F (-29°C)	400°F (204°C)
T	PTFE	-65°F (-54°C)	450°F (232°C)
G	Grafoil™ (SS Body) (CS Body)	-70°F (-56°C) -70°F (-56°C)	1000°F (537°C) 800°F (427°C)
D	Delrin™	-40°F (-40°C)	200°F (93°C)
P	Peek™	-40°F (-40°C)	400°F (204°C)
K	Kel-F™	-100°F (-73°C)	200°F (93°C)
Note: Grafoil™ is suitable for services in excess of 1000°F in a non-oxidizing environment.			

BONNET AND STEM DESIGN DETAILS

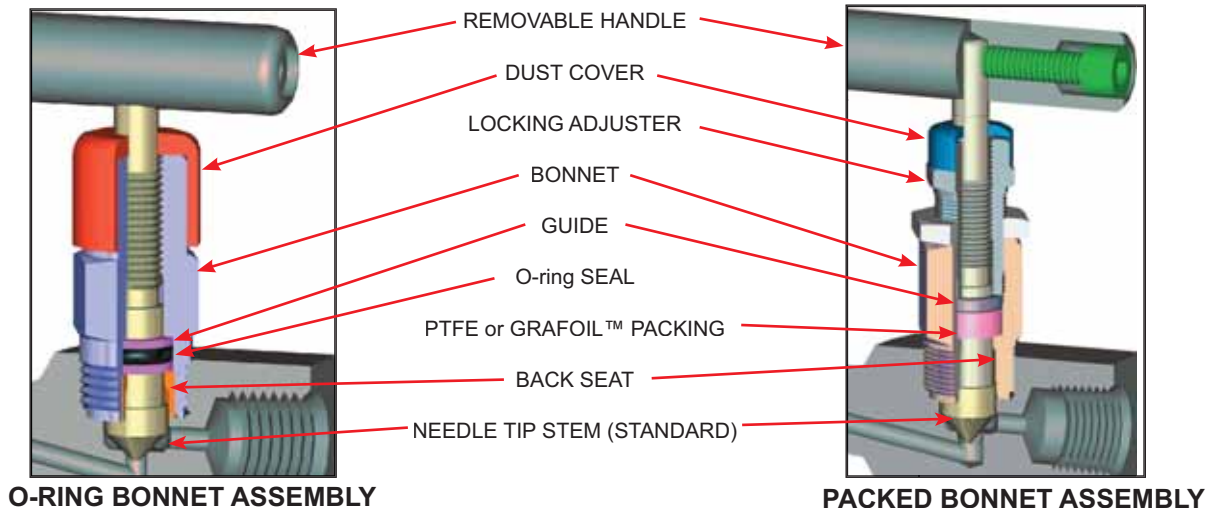

STEM AND SEAT CONFIGURATIONS

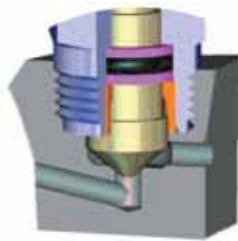

Mini Needle Tip
(Standard)

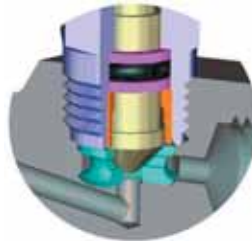

Mini Soft Seat
(Optional)

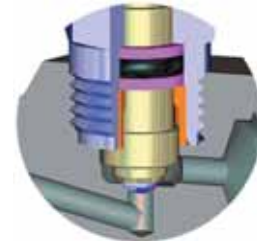

Mini Ball Tip
(Optional)

For further information please contact:

Phoenix Precision Ltd.
2620 21st Street N.E.
Calgary, Alberta T2E 7L3
Phone:(403) 291-3154
Fax: (403) 291-3292
email: phoenix@phoenixprecision.ca
www.phoenixprecision.ca

Distributor:



Phoenix Precision Ltd. (PPL) provides the information herein in good faith but makes no representation as to its comprehensiveness or accuracy. This data sheet is intended only as a guide to PPL products and services. Individuals using this data sheet must exercise independent judgment in evaluating product selection and determining product appropriateness for their particular purpose and system requirements. PPL MAKES NO REPRESENTATIONS OR WARRANTIES, EITHER EXPRESS OR IMPLIED, INCLUDING WITHOUT LIMITATION ANY WARRANTIES OF MERCHANTABILITY OR FITNESS FOR A PARTICULAR PURPOSE WITH RESPECT TO THE INFORMATION SET FORTH HEREIN OR THE PRODUCT(S) TO WHICH THE INFORMATION REFERS. ACCORDINGLY, PPL WILL NOT BE RESPONSIBLE FOR DAMAGES (OF ANY KIND OR NATURE, INCLUDING INCIDENTAL, INDIRECT, OR CONSEQUENTIAL DAMAGES) RESULTING FROM THE USE OF OR RELIANCE UPON THIS INFORMATION. Patents and Patents Pending in the U.S. and foreign countries. PPL reserves the right to change product designs and specifications without notice.

DELTRIN, VITON and TEFLON are registered trademarks (hereinafter referred to as TM) of E.I. Du Pont De Nemours and Company Corporation. PEEK is a registered TM of Whitford Worldwide Company and Whitford B.V. KEL-F is a registered TM of M.W. Kellogg Company. GRAFOIL is a registered TM of High Temperature Materials Inc. and Graftech INC. Corporation. AFLAS is a registered TM of Asahi Glass Co. Ltd. Corporation Japan. MONEL and INCONEL are registered TMs of Huntington Alloys Corporation. HASTELLOY is a registered TM of Haynes International, Inc.