

**Phoenix Precision's** NA10H series needle angle valves are built for the engineer and the instrumentation technician. These valves are optimal for high pressure applications and are rated up to 10,000 psi. The valves are burst tested at 53,000 psi. Both the O-ring and the packed stem seals offer advantages such as pinned bonnets, robust stems, precise packing, and large handles with rounded corners that make operation of the valves easy and comfortable. The O-ring version requires minimal maintenance, while the packed version offers a greater variety of materials for chemical and temperature compatibility, as well as an adjustable packing. The globe-pattern flow provides maximum shut-off and is available in needle tip, ball tip, and non-rotating tip configurations. As with all Phoenix valves, the packing is below the threads to prevent process contamination and corrosion. All Phoenix valves are built and tested in accordance with MSS SP105, which includes hydrostatic testing of the body at 150% rated pressure, seat leakage test of 150% rated pressure, and material test reports on body, bonnet, and stem as standard.



**Phoenix Precision has taken the guess work out of specifying valves. Phoenix Precision valves are designed and tested to meet or exceed the specifications below:**

- ▶ ASME B31.1 Power Piping
- ▶ ASME B31.3 Process Piping
- ▶ MSS SP-61 & ASME B16.34
- ▶ API 598 Valve Inspection and Testing
- ▶ MSS-SP105 Instrument Valves for Code Applications
- ▶ MSS-SP99 Instrument Valves
- ▶ MSS-SP25 Standard Marking Systems for Valves, Fittings, and Flange Unions
- ▶ NACE MR0175/ISO 15156 for all 316SS valves and A105CS body/316SS bonnet (SC-Material Code) valves in services with less than 50 ppm of chlorides
  
- ▶ ISO 9001:2000(E) Certified
- ▶ ABSA Design Registered CRN# 0C06740.2
  
- ▶ All valve assemblies are hydrotested at 150% of rated pressure as standard (shell test)
- ▶ All valves assemblies pass a seat leakage test at 150% of rated pressure as standard (seat test)
- ▶ MTR's on body, bonnet, and stem as standard
- ▶ All pressure component materials are sourced from U.S., Canada or Europe
- ▶ All packing below stem threads to prevent corrosion and contamination
- ▶ Metal body to bonnet seals are in compression not tension
- ▶ Back-seating to prevent stem blowout and provide a metal to metal secondary stem seal in full open position
- ▶ All stem threads are rolled for superior strength and to prevent galling
- ▶ O-ring stem seals come with additional Teflon™ top and bottom back-up rings
- ▶ Dust cap prevents lubricant washout and keeps contaminants out of bonnet assembly

**O-ring Bonnet Valve**

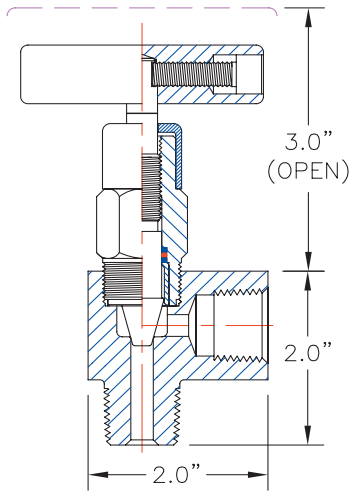

**Specifications:**

Type: Standard Valve, Globe Pattern  
 Rating: Up to 10000 psi @ 100°F\*  
 (68950 kPa @ 38°C)  
 Stem: Needle tip or Ball tip, or Non-rotating  
 Packing: FKM or Aflas<sup>TM</sup> O-ring  
 Seat: Integral  
 Handle: Removable  
 Bore Size: 3/16" to 1/4"  
 Inlet Connections: 1/4" to 1/2" NPT, SW or FT  
 Outlet Connections: 1/4" to 1/2" NPT, SW or FT  
 Bonnet Lock: Pin or Plate  
 Weight: 1.3 -1.4 lbs.  
 Special Service: O<sub>2</sub> or CL cleaning available\*  
 \*Other specifications or services may be available.

**Materials of Construction**

CODE	SS	SC	CS
Body	ASTM A182 316SS	ASTM A105CS	ASTM A108CS
Bonnet	ASTM A182 316SS	ASTM A182 316SS	ASTM A108CS
Stem	ASTM A182 316SS	ASTM A182 316SS	ASTM A582 303SS
Insert	ASTM A182 316SS	ASTM A182 316SS	ASTM A108CS
Handle	ASTM A582 303SS	ASTM A582 303SS	ASTM A108CS

**Packed Bonnet Valve**

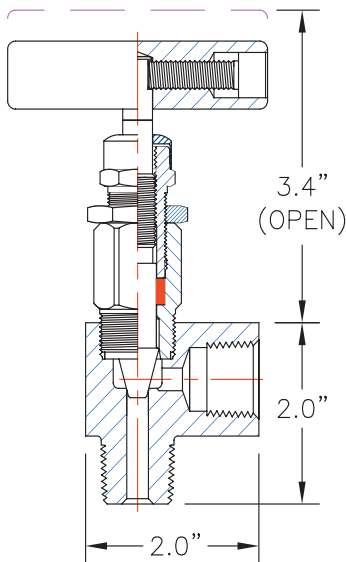

**Specifications:**

Type: Standard Valve, Globe Pattern  
 Rating: Up to 10000 psi @ 100°F\*  
 (68950 kPa @ 38°C)  
 Stem: Needle tip or Ball tip, or Non-rotating  
 Packing: PTFE or Grafoil<sup>TM</sup>  
 Seat: Integral  
 Handle: Removable  
 Bore Size: 3/16" to 1/4"  
 Inlet Connections: 1/4" to 1/2" NPT, SW or FT  
 Outlet Connections: 1/4" to 1/2" NPT, SW or FT  
 Bonnet Lock: Pin or Plate  
 Weight: 1.4 - 1.5 lbs.  
 Special Service: O<sub>2</sub> or CL cleaning available\*\*  
 \*Grafoil rated to 6000 psi  
 \*\* Other specifications or services may be available.

**Materials of Construction**

CODE	SS	SC	CS
Body	ASTM A182 316SS	ASTM A105CS	ASTM A108CS
Bonnet	ASTM A182 316SS	ASTM A182 316SS	ASTM A108CS
Stem	ASTM A182 316SS	ASTM A182 316SS	ASTM A582 303SS
Adjuster	ASTM A582 303SS	ASTM A582 303SS	ASTM A108CS
Insert	ASTM A182 316SS	ASTM A182 316SS	ASTM A108CS
Handle	ASTM A582 303SS	ASTM A582 303SS	ASTM A108CS

**Pressure vs. Temperature Chart 10000 psi**

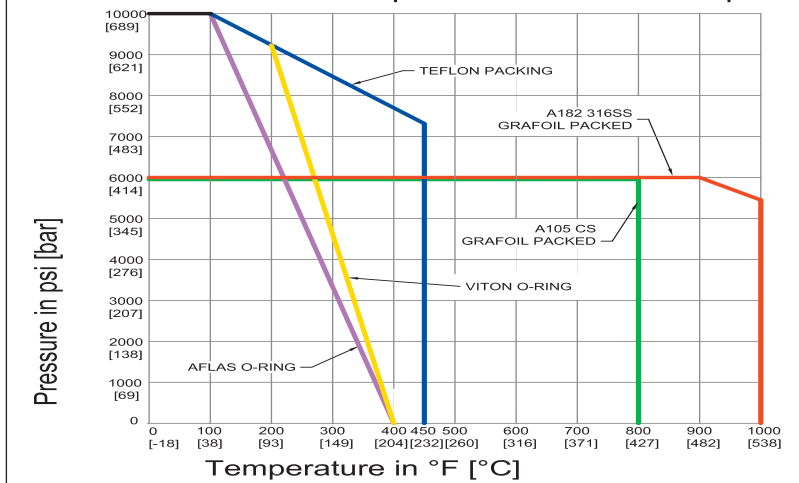

Note: Body material specifications based on ASME B16.34 - 2004. Packing materials based on manufacturer's specifications. Approximations only. Phoenix does not represent these values as finite. They are provided only as representative values.

## MODEL NUMBERING SYSTEM

Phoenix	Orifice Size	Type	Inlet Size	Inlet Type	Outlet Size	Outlet Type	Material	Packing	Seat	Stem Tip
P	3=3/16"	NA10H	4=1/4"	F=FNPT	4=1/4"	F=FNPT	SS=ASTM A182 316/316L	A=Aflas™	Integral (leave blank)	Needle Tip Standard (leave blank)
	4=1/4"		6=3/8"	M=MNPT	6=3/8"	M=MNPT	SC=ASTM A105 CS**	V=FKM		B=316SS Ball Tip
			8=1/2"	MS*=Male Socketweld	8=1/2"	MS*=Male Socketweld	CS=ASTM A108 CS**	T=PTFE		NR= Non-Rotating Needle Tip
				FS*=Female Socketweld		FS*=Female Socketweld	C5=ASTM A350 LF2	G=Grafoil™		BC=Ceramic Ball
				FT=Female Tube Fitting		FT=Female Tube Fitting	N4=Monel™ 400			BM=Monel™ Ball
							N6=Inconel™ 625			
							N8=Inconel™ 825			
							N2=Hastelloy™ C276			
EXAMPLE: P4NA10H8M8FSST = 1/4" Orifice, 1/2" MNPT Inlet, 1/2" FNPT Outlet, 316SS Body, PTFE Packing, Needle Tip Stem										
<b>P</b>	<b>4</b>	<b>NA10H</b>	<b>4</b>	<b>M</b>	<b>4</b>	<b>F</b>	<b>SS</b>	<b>T</b>		
*For socket weld (SW) connections, specify MS or FS. **For code applications, A108 CS is unacceptable, A105 CS must be selected for CS valves.										

OPTION CODES	DESCRIPTION
LB	Bonnet Lock
CC	Chlorine Clean
OC	Oxygen Clean
TG	SS Tag
SGL	Sour Gas ISO Nace Latest Rev.
PM	Panel Mount
N4	Monel™ 400 Stem
N5	Monel™ 500 Stem
N6	Inconel™ 625 Stem
N8	Inconel™ 825 Stem
N2	Hastelloy™ C276 Stem

### SEAL MATERIAL TEMPERATURE RATING

Code	Description	MIN. TEMP	MAX. TEMP
A	Aflas™	15°F (-10°C)	400°F (204°C)
V	FKM	-20°F (-29°C)	400°F (204°C)
T	PTFE	-65°F (-54°C)	450°F (232°C)
G	Grafoil™ (SS Body) (CS Body)	-70°F (-56°C) -70°F (-56°C)	1000°F (537°C) 800°F (427°C)
Note: Grafoil™ is suitable for services in excess of 1000°F in a non-oxidizing environment.			

**BONNET AND STEM DESIGN DETAILS**

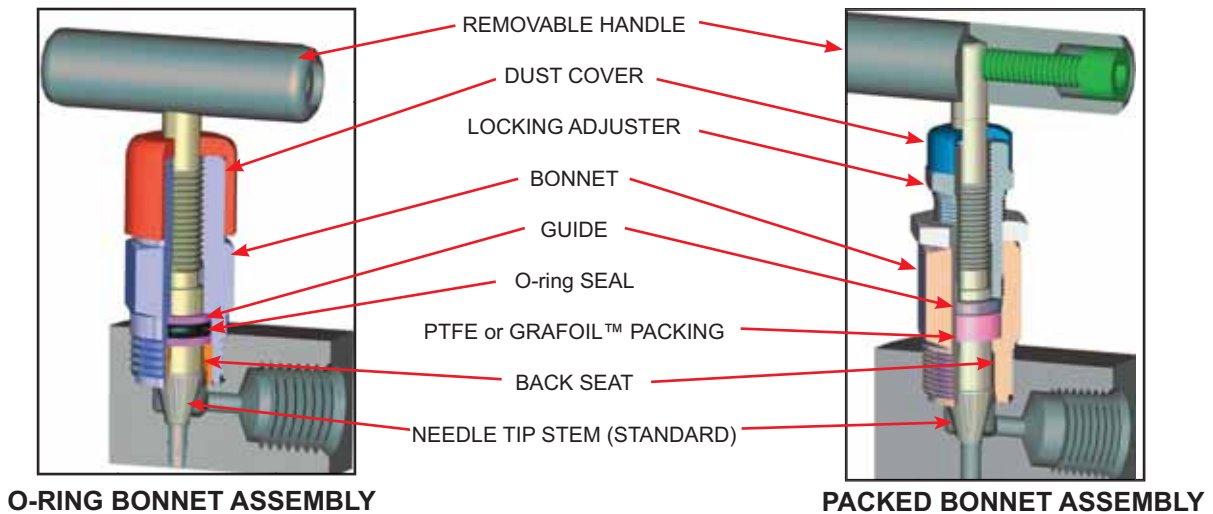

**STEM AND SEAT CONFIGURATIONS**

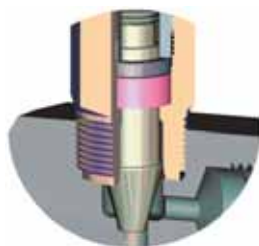

Needle Tip  
(Standard)

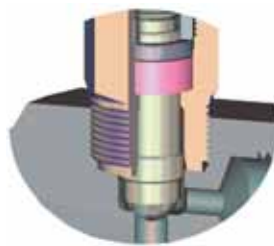

Ball Stem  
(Optional)

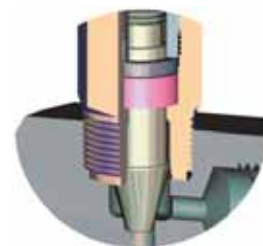

Non-Rotating  
(Optional)

For further information please contact:

Phoenix Precision Ltd.  
2620 21st Street N.E.  
Calgary, Alberta T2E 7L3  
Phone:(403) 291-3154  
Fax: (403) 291-3292  
email: phoenix@phoenixprecision.ca  
www.phoenixprecision.ca

Distributor:



Phoenix Precision Ltd. (PPL) provides the information herein in good faith but makes no representation as to its comprehensiveness or accuracy. This data sheet is intended only as a guide to PPL products and services. Individuals using this data sheet must exercise independent judgment in evaluating product selection and determining product appropriateness for their particular purpose and system requirements. PPL MAKES NO REPRESENTATIONS OR WARRANTIES, EITHER EXPRESS OR IMPLIED, INCLUDING WITHOUT LIMITATION ANY WARRANTIES OF MERCHANTABILITY OR FITNESS FOR A PARTICULAR PURPOSE WITH RESPECT TO THE INFORMATION SET FORTH HEREIN OR THE PRODUCT(S) TO WHICH THE INFORMATION REFERS. ACCORDINGLY, PPL WILL NOT BE RESPONSIBLE FOR DAMAGES (OF ANY KIND OR NATURE, INCLUDING INCIDENTAL, INDIRECT, OR CONSEQUENTIAL DAMAGES) RESULTING FROM THE USE OF OR RELIANCE UPON THIS INFORMATION. Patents and Patents Pending in the U.S. and foreign countries. PPL reserves the right to change product designs and specifications without notice.

DELTRIN, VITON and TEFLON are registered trademarks (hereinafter referred to as TM) of E.I. Du Pont De Nemours and Company Corporation. PEEK is a registered TM of Whitford Worldwide Company and Whitford B.V. KEL-F is a registered TM of M.W. Kellogg Company. GRAFOIL is a registered TM of High Temperature Materials Inc. and Graftech INC. Corporation. AFLAS is a registered TM of Asahi Glass Co. Ltd. Corporation Japan. MONEL and INCONEL are registered TMs of Huntington Alloys Corporation. HASTELLOY is a registered TM of Haynes International, Inc.